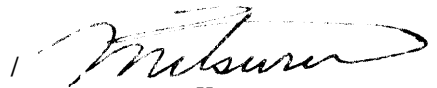

MODEL	Sorter for F21	VOLT/Hz	DATE OF MODIFICATION	SERIAL NO
MODIFIED ARTICLE	Parts Catalog			
REASON OF MODIFICATION	Parts Catalog Correction			

Please correct the following part number in your parts catalog:

Page	Index No.	Incorrect P/N	Correct P/N	Description	Q'ty
13	10	#58871111	#58871109	Front Support Bracket	1

M. Konno, Manager
Quality Assurance Department

Sorter for F21

CONTROL No. NO. <u>1</u>	v/Hz	DESTINATION	JAPAN PRODUCTION	
			CODE	SERIAL NUMBER
MODEL NAME				
RICOH CS2065	115/60	USA	A462-17	
RICOH CS2065	220,240/50	EUROPE, etc	A462-27	

M/B NO. : Master number of modification bulletin for this model.

CONTROL NO. : Reference number of modification bulletin for your model.

MODEL	Sorter for F21	VOLT/Hz	DATE OF MODIFICATION	SERIAL NO.
MODIFIED ARTICLE	Transport Belt Roller			
REASON OF MODIFICATION	To prevent the transport belts from moving out of the transport rollers			

DRAW. No.	OLD PARTSNO.	NEW PARTS NO.	DESCRIPTION	A.B.C	Q'TY USED OLD→NEW	INTER-CHANGE-ABILITY	PART NEEDED FOR REPLACEMENT BY NEW PART		PART CATALOG	
				RANK			PART NO.	DESCRIPTION	INDEX NO.	PAGE
	58873141		Transport Belt Roller		2 - 1				29	7
		A4623141	Transport Belt Roller		0 - 1	X / O			*31	7
									*:New Index	

- (1) : To replace new parts immediately.
 : To replace new parts at the time of repair.
 : To replace new parts at the time of overhaul.
- (2) When old and new parts are not mutually interchangeable, use additional parts or an assembly part indicated in " PARTS NEEDED FOR REPLACEMENT BY NEW PART" to install the new part.
- (3) Left mark indicates whether old part can be used in new machine or not.
 Right mark indicates whether new part can be used in old machine or not.

DETAILS OF MODIFICATION

MANUAL PAGE

2. TRANSPORT 1 (A029) (Page 6)

To prevent the transport belts from moving out of their correct positions on the transport rollers, one of the transport belt rollers has been changed to the rounded type as shown in the illustration. As a result, when the transport belts start meandering, the new roller returns them to their correct positions.

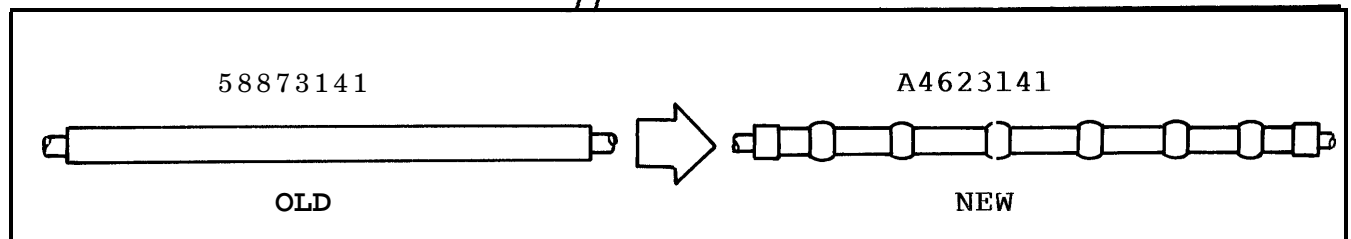
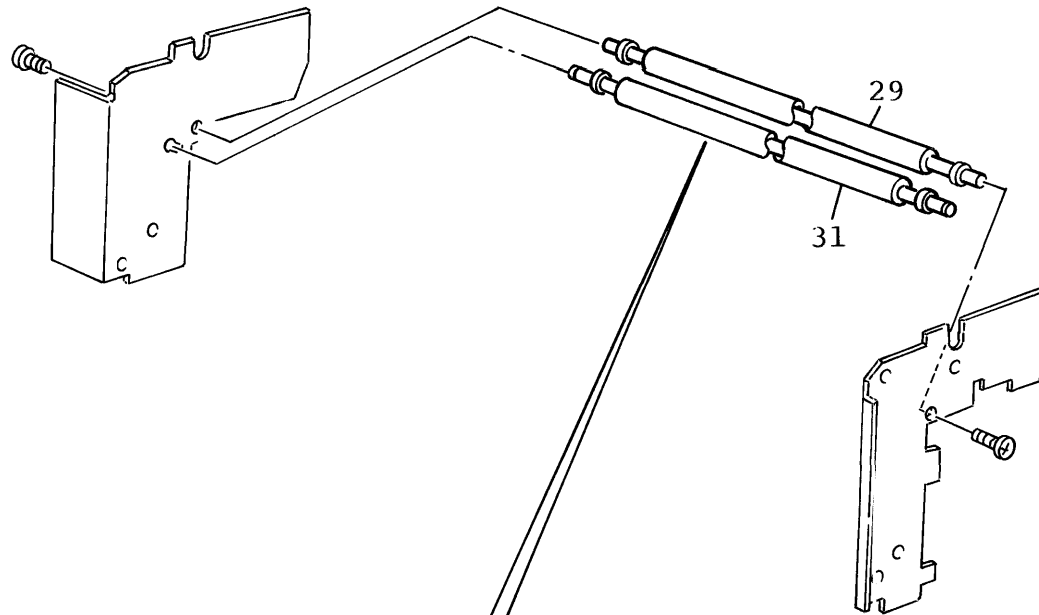

M. Konno, Manager
Quality Assurance Department

Sorter for F21

CONTROL No. NO. <u>2</u>	v/Hz	DESTINATION	JAPAN PRODUCTION	
MODEL NAME			CODE	SERIAL NUMBER
RICOH CS2065	115/60	USA	A462-17	245005XXXX
RICOH CS2065	220,240/50 _p	EUROPE, etc	A462-27	2450030001

M/B NO. : Master number of modification bulletin for this model.

CONTROL NO. : Reference number of modification bulletin for your model.

Model	Sorter for F21 and F22	Volt/Hz	Date of Modification	Serial Number
Modified Article	Magnet Catch			
Reason for Modification	Parts standardization			

Due to parts standardization, the following part has been changed. The interchangeability is O/O.

Page	Index	Old P/N	New P/N	Description
5	20	50540536	AG070004	Magnet Catch Ass'y

T. Ito, Manager
Copier Technical Support

MODEL NAME	V/Hz	DESTINATION	CODE	SERIAL NUMBER
Sorter for SAVIN9710	115/60	USA	A462-15	385112XXXX
RICOH CS2065	115/60	USA	A462-17	245112XXXX
HCS Sorter 9165	220, 240/50	EUROPE	A462-26	386121XXXX
RICOH CS2065	220, 240/50	EUROPE	A462-27	245112XXXX

Model	Sorter for F21 and F22	Volt/Hz	Date of Modification	Serial Number
Modified Article	Magnet Catch			
Reason for Modification	As per request from production line			

The magnet catch was changed from # 50540536 to # AG070004 due to the parts standardization (MB - 3) .
 But, production line requested to return the part to 50540536 because 50540536 is easier to install in production line.

Old P/N	New P/N	Description	Q'ty Used	Interchangeability	Parts Catalog	
					Index No.	Page
AG070004	50540536	Magnet Catch Ass'y	1 → 1	X/O	20	5

T. Ito, Manager
 Copier Technical Support

MODEL NAME	V/Hz	DESTINATION	CODE	SERIAL NUMBER
Sorter for SAVIN9710	115/60	USA	A462-15	385208XXXX
RICOH CS2065	115/60	USA	A462-17	2452040001
HCS Sorter 9165	220, 240/50	EUROPE	A462-26	386082XXXX
RICOH CS2065	220, 240/50	EUROPE	A462-27	245208XXXX